



---

**| Hard Chrome Plated Rod**  
**| Induction Harden Rod | Honed Tubes**

Plot No. 362/3, Road No.7, Opp. Pooja Engineers,  
Kathwada GIDC, Ahmedabad-382430, Gujarat, INDIA.

☎ +91 9426174756

✉ info@chromearod.com

☎ +91 7990236114

✉ sales@chromearod.com

🌐 www.chromearod.com



**ISO 9001 : 2015 CERTIFIED COMPANY**



## HARD CHROME PLATED ROD

Hard Chrome Plated Shafts (Hard Chrome Plated Bars) and hardened hard plated chrome bar are designed to meet your specific needs for piston rod material in Hydraulic and Pneumatic Cylinders and other applications. Most advanced techniques of surface removal, polishing and hard chrome plating are used in manufacturing the above bars.

Material	: EN-8 D/CK45 standard available EN-8 / EN-19 / EN-31/ other as per requirement.
Standard Size	: 6mm to 300mm.
Standard Length	: 3mtr-7mtr (Can provide cut lengths as per request)
Hard Chrome Plating thickness	: 0 < 20 mm : min. 15 Micron 0 20 mm : min. 20 Micron
Surface Roughness	: Better than RA - 0.2
Chrome Surface Hardness	: Min. 800 HV
Straightness	: Ø 16 mm : max. 0.3 mm / 1000 mm Ø > 16 mm : max. 0.2 mm / 1000 mm
Od Tolerance	: f7 / f8 /

## INDUCTION HARDEN ROD

We pride ourselves on the quality of our products, which go through a highly specific production process. Each Chrome Plated Rod we ship has been inspected to meet current industry Standards for tolerances.

Induction Hardened Chrome Plated Steel Bars are produced by using advanced techniques on AISI 1045/1050 Steel Bars, for surface removal, polishing, induction hardening and then hard chrome plating. The finished product is a superior impact resistant bar ideal for high quality piston rods.

Material Grade	: EN8-D, Ck45 standard available (EN-8/EN-19 /EN-31/Others as per request)
Standard Size	: Ø6 - 300 mm
Diameter tolerance	: ISO f7/18 (other on request)
Roundness	: Max. 1/2 from diameter tolerance
Standard Length	: 3 mtr - 7 mtr (On request cut lengths and special lengths)
Surface Roughness	: Ra : Max. 0.20 µm
Hardness Case Depth	: 1.5 mm to 2.5 mm
Chrome Layer Thickness	: Ø < 20 mm : min. 15 µm Ø ≥ 20 mm : min. 20 µm
Surface hardness	: Min. 800HV
Straightness	: Ø ≤ 16mm : Max. 0.3 mm/1000 mm Ø > 16 mm : Max. 0.2 mm/1000 mm
Hardness	: 58±2HRC

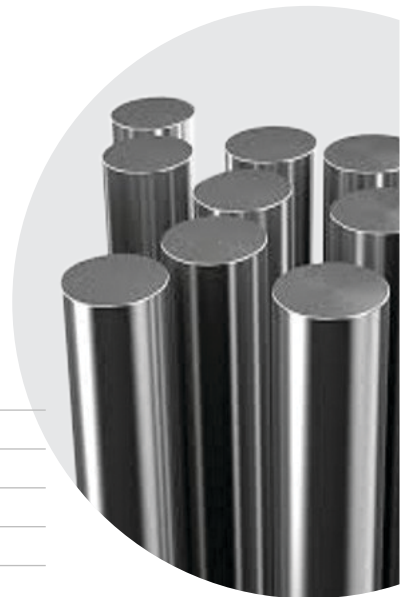

## SEAMLESS HONED TUBE & READY TO HONE TUBE

We have in store for our clients, a resilient range of honed tubes that find application in pneumatic and hydraulic cylinders. Made from fine quality seamless pipe, our range is made use of in several industries and machinery including earth moving machinery.

Delivery Condition	: DIN2391 BK+S St52
	Hone / SRB / CDS
ID tolerance (Honed/SRB)	: HB
Dimensions	: ID 32 - ID600
Lenght	: 3 mtr. - 7 mtr.

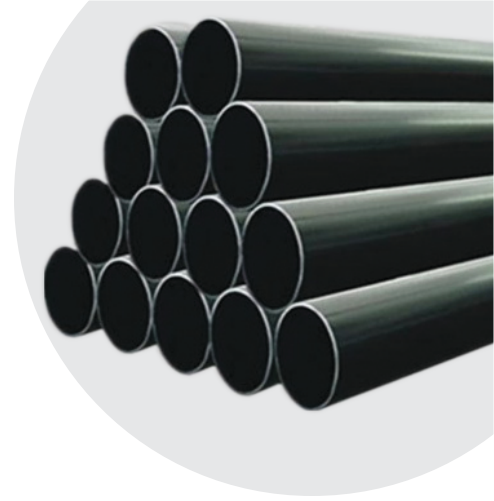

## L M SHAFT

Usage Shaft for L. M. Bearing / Piston Rod for 1M bearing moving equipment shaft for fitness equipment Guide Pillar, Side Rail.

Material Grade	: EN-8 D/CK45 standard available
	EN-8 / EN-19 / EN-31/ other as per requirement.
Standard Size	: 6mm to 300mm.
Standard Length	: 3mtr-7mtr (Can provide cut lengths as per request)
Hard Chrome Plating thickness	: 20 to 25 Micron
Surface Roughness	: 0.2 RA
Hardness	: 60 HRC $\pm$ 2
Surface Hardness	Min. 800 HV
Hardness Case Depth	: 1.5 mm to 2.5 mm
Straightness	: 0.2 per meter max.
Od Tolerance	: g6 / f7

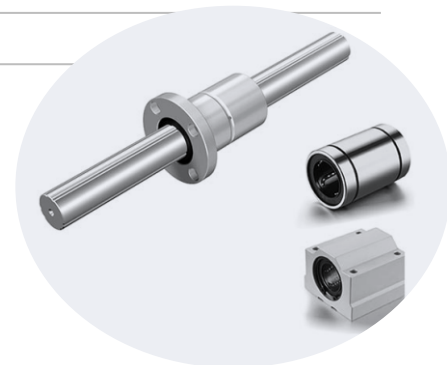
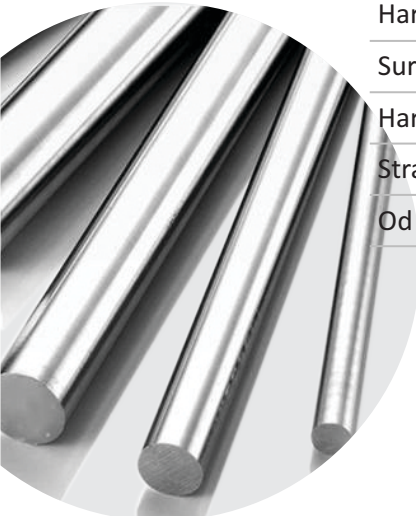



## ISO 9001 : 2015 CERTIFIED COMPANY

Plot No. 362/3, Road No.7, Opp. Pooja Engineers, Kathwada GIDC, Ahmedabad-382430, Gujarat, INDIA.

☎ +91 9426174756 | 7990236114 ✉ info@chromeard.com | sales@chromeard.com

🌐 www.chromeard.com

### ABOUT US

CRTC shaft company is working under the engineering and fluid power industry experts who are having deep experience in the similar field. CRTC design, manufacture, supply of hydraulic equipment the READY TO HONED TUBES, HARD CHROME PLATED RODS, INDUCTION HARDEN ROD, LM SHAFT, READY TO HONE TUBE etc. along with customized Hydraulic systems for almost every industries.

The company's service offerings have since greatly expanded and its name has come to represent quality, reliability and trust. Today with significant industry experience the firm has evolved horizontally and vertically to become both a manufacturer as well as distributor.

### MISSION

To serve the Indian industry with new techniques in automation with latest technology to improve the production rate without compromising in quality with the best commercial package.

### OBJECTIVE

CRTC's objectives is customer satisfaction, underscored by sustained confidence in our products and services. CRTC's combination of products and services represents a total package. CRTC's combine expert, professional advice with the ability to deliver the desired.

#### INDEX

Hard Chrome Plated Rod

Induction Harden & Hard Chrome Plated Rod

L M Shaft

Seamless Hone / SRB Tube

Ready to Hone Tube

